



User Manual

CoolSculpting System

(ZELTIQ Breeze System)



ZELTIQ Aesthetics, Inc.
4410 Rosewood Drive
Pleasanton, CA 94588 USA
(925) 474-2500
www.coolsculpting.com



ZELTIQ Customer Service
Worldwide: (+1) 925-474-8160
USA: (+1) 888-935-8471
(1-888-ZELTIQ1)



Preface

Contents

- Intellectual Property 2
- Intended Use 2
- Contraindications 2
- Warnings 3
- Treatment Sites 4
- Cautions 5
- Side Effects 5
- Potential for Tissue Damage 6
- ZELTIQ Customer Service 6
- About the System 6
- System Symbols 7
- User Documentation 8

Intellectual Property

Copyright © 2018 ZELTIQ Aesthetics, Inc. All rights reserved. Unauthorized duplication or use is prohibited. COOLSCULPTING®, ZELTIQ®, and FREEZE DETECT® are registered trademarks of ZELTIQ Aesthetics, Inc. The procedures described in this document are covered by U.S. Patent 7,367,341. Additional issued patents and patent applications pending worldwide relate to the products and procedures described in this document.

WARNING: Unauthorized modification or repair of the control unit, its components, or supplies may result in unsafe conditions and/or impaired performance. No modification of this equipment is allowed without express authorization from ZELTIQ. Any unauthorized modification or repair will void the warranty.

Intended Use

The CoolSculpting® System, also labeled as the ZELTIQ® System or the ZELTIQ® Breeze System (system), is a non-invasive thermoelectric cooling and heating device that applies controlled cooling or heating to a treatment site on the patient’s skin.

Uses of the system in cooling mode include:

- Fat layer reduction through cold-assisted lipolysis.
- Minimizing pain and thermal injury during laser and dermatological treatments.
- Acting as a local anesthetic for procedures that induce minor local discomfort.

The system can also provide localized thermal therapy (hot or cold) to minimize pain for post-traumatic and/or post-surgical pain and to temporarily relieve minor aches and pains and muscle spasms. The optional massage function can also be used for:

- Temporary relief of minor muscle aches, pain, and spasm.
- Temporary improvement in local circulation.

Contraindications

Localized skin cooling is contraindicated in patients who have:

- Cryoglobulinemia

- Cold agglutinin disease
- Paroxysmal cold hemoglobinuria
- Areas of impaired peripheral circulation
- Pregnancy and lactation

Use of the ZELTIQ System for lipolysis should not include areas of the body with a subcutaneous fat layer thickness of less than 1 cm.

Warnings

Use of the CoolSculpting System has not been studied in children, or in patients with:

- Known sensitivity to cold such as cold urticaria or Raynaud's disease, or Chilblains (pernio)
- Known sensitivity or allergy to fructose, glycerin, isopropyl alcohol, or propylene glycol
- Impaired peripheral circulation in the area to be treated
- Neuropathic disorders such as post-herpetic neuralgia or diabetic neuropathy
- Scar tissue or extensive skin conditions such as eczema, or dermatitis at the area of intended treatment
- Impaired skin sensation
- Open or infected wounds
- Bleeding disorders or concomitant use of blood thinners
- Recent surgery or scar tissue in the area to be treated
- Hernia in or adjacent to the treatment site
- Skin conditions such as eczema, dermatitis, or rashes in the area to be treated
- Areas of recent bleeding or hemorrhage (heating)

The effect of performing a CoolSculpting treatment (treatment) with a vacuum applicator on a patient who has a hernia in or adjacent to the treatment site has not been studied. The applicator uses vacuum pressure to draw tissue into the applicator cup during the treatment. The vacuum pressure may therefore apply pressure on a pre-existing hernia or pre-existing structurally weak area such as a surgical scar, causing further complications. Physicians should examine the patient for evidence of pre-existing abdominal or femoral hernia prior to use of the device.

The system operates at temperatures below 0°C, which can freeze tissue; clinical events that are common to freezing tissue should be considered.

The use of this device on areas with superficially located nerve branches, arteries, or veins has not been demonstrated to be safe and effective. Such use may result in injury to the patient.

The effect of performing treatments directly over active implanted devices in patients, such as pacemakers and defibrillators, is not known.

Use of the system may result in temporary numbness or a tingling sensation in the treated area that may last for up to several weeks after treatment.

Patients with chronic pain, sensitivity to cold, or an anxiety disorder may be more prone to pain or discomfort during the treatment.

The use of other electronic medical devices on a patient who is undergoing a treatment might interfere with the correct functioning of the system, possibly resulting in injury to the patient. Do not use other electronic medical devices on a patient who is undergoing a treatment.

WARNING: Before using the system, read and understand the User Documentation set. See User Documentation on page 8.

Treatment Sites

Observe the following warnings when treating the submental and submandibular areas:



Treatment Site	Warning
 <p data-bbox="305 772 516 804">Hypoglossal Nerve</p>	<p data-bbox="638 373 1052 499">WARNING: Cold exposure to the hypoglossal nerve may cause tongue deviation following treatment of the submental and submandibular areas.</p>
 <p data-bbox="256 1260 565 1291">Marginal Mandibular Nerve</p>	<p data-bbox="638 867 1068 1024">WARNING: Cold exposure to the marginal mandibular nerve may cause lower lip weakness following treatment of the submental and submandibular areas.</p>
 <p data-bbox="289 1738 532 1770">Submandibular Gland</p>	<p data-bbox="638 1350 1068 1507">WARNING: Cold exposure to the submandibular gland may cause xerostomia, or decrease in saliva production, following treatment of the submental area.</p>

Table 1: Submental and Submandibular Areas Treatment Warnings

Observe the following warning when treating the upper arm:

Treatment Site	Warning
 <p data-bbox="342 667 477 695">Ulnar Nerve</p>	<p data-bbox="639 331 1052 426">WARNING: Avoid compression of the ulnar nerve during treatment of the upper arm.</p>

Table 2: Upper Arm Treatment Warning

Cautions

The system is intended for use by a trained physician or a physician-designated medical professional.

Fat layer reduction has been demonstrated for at least 6 months after the treatment. Longer-term studies have not been completed to demonstrate sustained fat layer reduction beyond this time period.

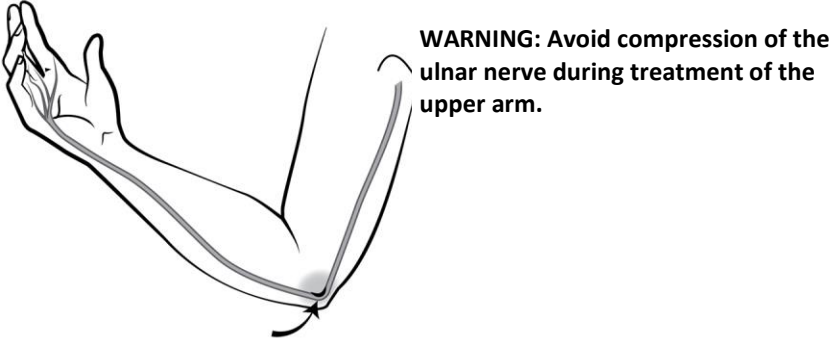
If the operator observes a potential safety issue or operational abnormality during use, the treatment should be terminated and ZELTIQ Customer Service should be contacted promptly.

The use of other equipment and supplies with the system has not been tested and may cause unexpected results.

Side Effects

The following effects can occur in the treatment area during and after a treatment. These effects are temporary and generally resolve within days or weeks.

During a treatment:

- Sensations of pulling, tugging, and mild pinching.
- Intense cold, tingling, stinging, aching, cramping. These sensations subside as the area becomes numb.

Immediately after a treatment:

- Redness and firmness.
- Transient blanching and/or mild bruising around the edges of the treatment area.
- Tingling and stinging.

One to two weeks after a treatment:

- Redness, bruising, and swelling.
- Tenderness, cramping, and aching.
- Itching, skin sensitivity, tingling, and numbness. Numbness can persist up to several weeks after a treatment.
- Sensation of fullness in the back of the throat after submental area treatment.

Rare Side Effects

- Paradoxical hyperplasia: Visibly enlarged tissue volume within the treatment area, which may develop two

to five months after treatment. Surgical intervention may be required.

- Late-onset pain with a typical onset several days after a treatment and resolution within several weeks.
- Freeze burn: First and second degree freeze burn may occur during treatment. It typically resolves without sequelae with proper care.
- Vasovagal symptoms: Dizziness, lightheadedness, nausea, flushing, sweating, or fainting during or immediately after the treatment.
- Subcutaneous induration: Generalized hardness and/or discrete nodules within the treatment area, which may develop after the treatment, and may present with pain and/or discomfort.
- Hyperpigmentation: Hyperpigmentation may occur after treatment. Typically, it resolves spontaneously.
- Hernia: Treatment may cause new hernia formation or exacerbate pre-existing hernia, which may require surgical repair.
- Treatment Area Demarcation (TAD): An aesthetic outcome of treatment in which the patient experiences excessive fat removal in the treatment area, resulting in a visible disruption to the continuous contour of fat, or unwanted indentation in the treated area.
- Cold panniculitis: Cold panniculitis results from injury to adipose tissue exposed to cold and may result in a mild to severe inflammatory response. In mild cases, the symptoms are self-resolving and may include redness, swelling, skin nodules, warmth, tenderness, and possible low-grade fever. These cases typically resolve without long-term sequelae. In more severe cases, an intense inflammatory response may result in more extensive tissue damage, including fat necrosis, which may require medical or surgical intervention.

Freeze burn, vasovagal symptoms, and hyperpigmentation were observed during clinical trials, while the others were reported in post market use.

Potential for Tissue Damage

The system operates at temperatures below 0°C, which can freeze tissue. Therefore, the system monitors tissue during cooling and employs multiple safety features including the Freeze Detect® system, to minimize the risk of damage to tissue. In spite of these measures, on rare occasions, the Freeze Detect system can detect a possible freeze condition.

The Freeze Detect system is comprised of several features, including thermal sensors and proprietary algorithmic software. Freeze Detect is an integral part of the CoolSculpting System and is automatically employed when a treatment is initiated. When the Freeze Detect system detects a possible freeze condition, it stops the treatment and displays a Z409 message. If you receive this message, remove the applicator and gelpad or gel, and assess the tissue before taking further action. If you receive a second Z409 message for one treatment site, discontinue the treatment. Failure to follow instructions could result in injury to the patient, including first- or second-degree burns. Second-degree burns or complications of second-degree burns may result in hypopigmentation.

ZELTIQ Customer Service

- Worldwide: (+1) 925-474-8160
- U.S.A.: 1-888-935-8471 (1-888-ZELTIQ1)

About the System











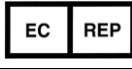

















The system is comprised of a control unit, a surface or vacuum applicator, and supplies. The applicators, foam borders, gelpads, gel, liners, pretreatment skin wipes, and securement systems are patient -applied parts.

During a treatment, the operator applies a gelpad or gel and applicator to the patient's skin. The vacuum applicator draws tissue into the applicator cup and holds the tissue against the cooling surfaces of the applicator; the surface applicator does not use vacuum pressure. The operator starts the treatment. Sensors in the cooling surfaces of the applicator monitor the skin surface, providing feedback that controls the rate of

heat flux. The gelpad or gel protects the skin by providing thermal coupling at the interface between the cooling surfaces of the applicator and the skin. The card provides cycles and profiles for use with the system.

System Symbols

The following symbols are used on the components of the system and on its supplies and packaging.

	Manufacturer		Authorized Representative in the European Community
	Follow instructions in the user manual and directions for use		Consult instructions for use (user manual, directions for use)
	CE Marking		Caution
	Do not reuse		Do not use if package is damaged
	Type BF -- Floating patient applied parts. Not for use in conjunction with defibrillators.		Potential for Electromagnetic Interference
	Catalog number		Serial number
	Quantity		Lot number
	Protective earth ground		WARNING: High voltage
	Equipotential contact		Alternating current
	Use by		Special disposal methods are required for this electrical device. Refer to local and national regulations.
	Locked position		Unlocked position
	On (Power)		Off (Power)
	Peel here		Single patient use
	Regulatory Compliance Mark (Australia)		cTUVus: Meets minimum electrical safety standards of Canada and the USA.
	CAUTION: Federal Law (USA) restricts this device to sale by or on the order of a physician		Machine wash, cold



	Do not bleach		Tumble dry gentle, low heat
	Do not iron		Do not dry clean

Table 3: System Symbols

For information on symbols and indicators that are displayed on the screen, see System Overview on page 11.

User Documentation

Note: All images in ZELTIQ user documentation are sample images. Your hardware and information on the system screen may differ from those depicted in the documentation.

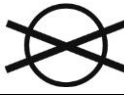
User Manual

The User Manual provides detailed information on the components of the system, contraindications and side effects, performing treatments, troubleshooting, and cleaning, and maintenance.

Directions for Use

A directions for use document is included with each applicator and with supplies. The document provides up-to-date information on safety and usage. Refer to the most recent directions for use for each item.

ZELTIQ reserves the right to modify the content of the user documentation at any time. Retain the most current user documentation and always review it prior to using any component of the system.

Conventions in User Documentation

Name	Description
Note	Additional information that is not associated with risk.
Caution	Use or misuse of the device is associated with risk of minor temporary injury and damage to equipment.
Warning	Use or misuse of the device is associated with risk of serious and/or permanent injury and death.

Table 4: Conventions in User Documentation

Table of Contents

Preface	2
Intellectual Property	2
Intended Use	2
Contraindications	2
Warnings	3
Treatment Sites	4
Cautions	5
Side Effects	5
Potential for Tissue Damage	6
ZELTIQ Customer Service	6
About the System	6
System Symbols	7
User Documentation	8
Chapter 1 System Overview	11
Control Unit	11
Applicators	21
Supplies	21
Chapter 2 Treatment	23
Overview	23
Perform a Treatment	23
Perform Another Treatment	31
Cancel a Treatment	33
About Restarting a Treatment	34
Complete a Treatment	35
Chapter 3 Cleaning and Maintenance	39
Cleaning	39
Maintenance	40
Disassembling the Control Unit	43
Assembling the Control Unit	46
Connecting Latches, Hoses, and Cables	47
Customer Service	48
Appendix A System Messages	49
ZELTIQ Customer Service	49
Recoverable Exceptions	49
Error Messages	51
General Messages	51
Software Updates and Messages	52
Appendix B System Tools	55
Controls for System Tools	55
System Log Screen	55
Card Log Screen	56

Service Screen	58
Settings Screen	60
Appendix C System Specifications	65
Essential Performance	65
Disposal of Hazardous Materials	65
Environmental Requirements	65
Electrical Specifications	66
Medical Safety Standards	66
Electromagnetic Compatibility	66
Data Modem Specifications	70

CHAPTER 1

SYSTEM OVERVIEW

Contents

- Control Unit 11
- Applicators..... 21
- Supplies..... 21

This chapter describes the system.

Control Unit

The control unit is a portable device that is used to start, stop, and monitor treatments.

- Control Unit - Front View on page 11
- Control Unit - Rear View on page 18

Control Unit - Front View



Components - Front View

1. Rail: When the applicator is resting on top of the control unit, the rail helps keep the applicator in place. In addition, the rail is used as a handle to move the system.
2. Vents: Vents provide airflow that reduces heat build-up inside the control unit. Ensure all vents are free from obstructions when the control unit is in operation.
3. Drawer: The drawer provides storage space for supplies and user documentation.
4. Casters and Locks: The control unit has four casters that swivel. Each caster has a lock. Always engage the locks on all four casters before you use the control unit.
5. Screen: The screen displays system controls, information about the status of the system, information about the treatment, and messages for the operator.

► **To engage and release the locks:**

1. Press down on the locking lever with the toe of your shoe.
2. Pull up on the locking lever with the toe of your shoe.

General Controls and Cues on the Screen

The screen on the control unit displays cues and control buttons.













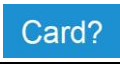















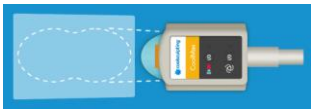

Button	Description	Name
	Pay attention to safety concerns.	Caution
	Connect the applicator to the control unit.	Applicator? Cue
	Insert the card into the slot on the applicator.	Card? Cue
	Display the list of profiles.	Display Profiles
	Go to the next screen.	Next
	Go to the previous screen.	Previous
	Increase (Date and Time settings)	Increase
	Decrease (Date and Time settings)	Decrease
	Start	Start
	Cancel	Cancel
	Interrupt	Interrupt
	Press Yes to confirm the selection	YES Button
	Press No to cancel the selection	NO Button
	Indicates that the system is cooling in preparation for treatment. If this cue persists, contact Customer Service.	Cooling Cue
	Indicates that the system is warming in preparation for treatment. If this cue persists beyond 2 minutes, contact Customer Service.	Warming Cue
	Displays the time remaining in which to restart an interrupted treatment.	Restart Timer

Table 5: General Controls and Cues

Controls and Cues for Standard Vacuum Applicators

Note: See also the directions for use for CoolAdvantage and CoolMini applicators.

The screen on the control unit displays the following controls and cues when a standard vacuum applicator is connected to the control unit.

Button	Description	Name
	Install the liner onto the vacuum applicator.	Liner?
	Do not use a gelpad that has wrinkles or tears (left). Ensure that the gelpad is smooth and without tears (right).	Gelpad Placement Cue
	Press to indicate that a new gelpad is on the treatment site.	GELPAD?
	Indicates that the gelpad was confirmed.	Gelpad Confirmed
	Place the applicator over the center of the gelpad.	Vacuum Applicator Placement Cue
	Place the applicator on the treatment site and wait until the Start button is displayed.	Tissue Draw
	Prompts you to activate or deactivate vacuum pressure.	Activate / Deactivate Vacuum pressure.
	Vacuum	Vacuum
	Massage	Massage
	Off - Press to turn on.	Off
	On - Press to turn off.	On
	View and modify vacuum settings for the treatment.	Vacuum Settings
	Display message settings	Display
	Hide message settings	Hide
	Modify vacuum settings for massage.	Max and Min Message Settings















Button	Description	Name
	Increase	Increase
	Decrease	Decrease
	Indicates that the system is preparing for the next action.	Progress Indicator

Table 6: Controls and Cues - Standard Vacuum Applicator

Controls and Cues for CoolAdvantage Applicators

Note: See also the CoolAdvantage Directions for Use.

The screen on the control unit displays the following controls and cues when a CoolAdvantage applicator is connected to the control unit.

Button	Description	Name
	Do not use a gelpad that has wrinkles or tears (left). Ensure that the gelpad is smooth and without tears (right).	Gelpad Placement Cue
	Press to indicate that a new gelpad is on the treatment site.	GELPAD?
	Indicates that the gelpad was confirmed.	Gelpad Confirmed
	Prepare the applicator with gel trap, gasket, and contour.	Applicator Preparation Cue
	Press to indicate that the required preparation is complete.	CONFIRM?
	Indicates that the preparation was confirmed.	CONFIRMED
	Place the applicator over the center of the treatment site.	Applicator Placement Cue
	Place the applicator on the treatment site and wait until the Start button is displayed.	Tissue Draw
	Prompts you to activate or deactivate vacuum pressure.	Activate / Deactivate Vacuum pressure
	Vacuum	Vacuum
	Off - Press to turn on.	Off















Button	Description	Name
	On - Press to turn off.	On

Table 7: Controls and Cues - CoolAdvantage Applicators

Controls and Cues for the CoolMini Applicator

Note: See also the CoolMini Directions for Use.

The screen on the control unit displays the following controls and cues when a CoolMini applicator is connected to the control unit.

Button	Description	Name
	Apply gel to the treatment site.	Gel Cue
	Press to indicate that new gel is on the treatment site.	GEL?
	Indicates that the gel was confirmed.	Gel Confirmed
	Press to indicate that a gel trap is in the slot in the applicator cup.	Gel Trap Cue
	Insert a gel trap into the slot in the applicator cup.	GEL TRAP?
	Place the applicator over the center of the treatment site.	Applicator Placement Cue
	Place the applicator on the treatment site and wait until the Start button is displayed.	Tissue Draw
	Prompts you to activate or deactivate vacuum pressure.	Activate / Deactivate Vacuum
	Vacuum	Vacuum
	Off - Press to turn on.	Off
	On - Press to turn off.	On
	View and modify vacuum settings for the treatment.	Vacuum Settings
	Increase	Increase

Button	Description	Name
	Decrease	Decrease

Table 8: Controls and Cues - CoolMini Applicator

Controls and Cues for the Surface Applicator

The screen on the control unit displays the following cues and controls when a surface applicator is connected to the control unit.



Button	Description	Name
	Apply foam borders, gelpad, and liner.	Surface Applicator Site Preparation Cue
	Press to indicate that the required site preparation is complete.	CONFIRM? Site Preparation
	Indicates that site preparation was confirmed.	Site Preparation Confirmed
	Place the applicator between the borders and attach the securement system.	Surface Applicator Placement Cue

Table 9: Controls and Cues - Surface Applicator

Patient Data Controls





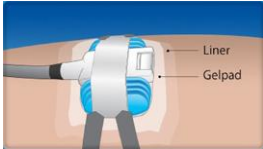

Button	Description	Name
	The patient is new to the practice.	New to Practice
	The patient is returning to the practice.	Returning to Practice
	The patient is female.	Female Patient
	The patient is male.	Male Patient
	Perform another treatment on the same patient.	Same Patient
	Perform a treatment on the next patient.	Next Patient

Table 10: Patient Data Controls

Note: If the Patient Data controls are not displayed, contact Customer Service.

Body Profile Screen

The Body Profile screen shows outlines of a male or female patient. In this example, a female patient is displayed.

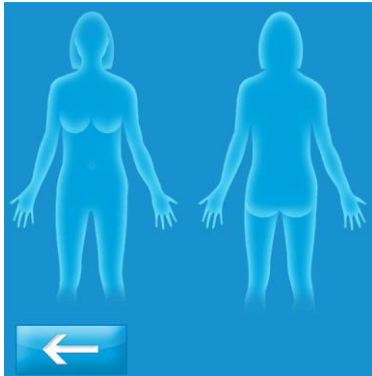

► **To select a treatment site:**

1. Press the desired body part.

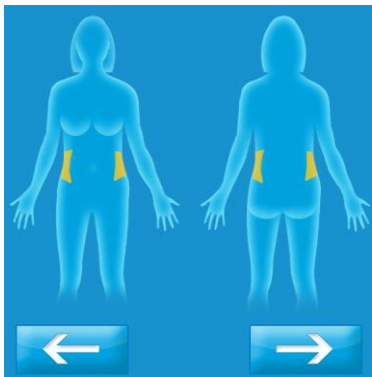

If the selected part is not available, the system emits a tone.
In this example, the flanks are selected for a female patient.

Progress Bar

The Progress Bar displays information about the current treatment.
In the examples below, a vacuum profile is presented.

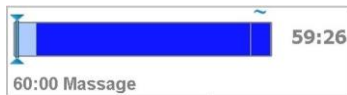



Sample	Description
60:00	Duration of the treatment in MM:SS or H:MM:SS. (H = hours, MM = minutes and SS = seconds). This treatment will last 60:00 minutes.
	The treatment progress indicator shows the current stage of the treatment.
	(Vacuum applicator only) Massage: The tilde appears above a segment that includes massage.

Table 11: Progress Bar

Audible Tones

The control unit beeps:

- When the operator presses a button on the screen

- When the operator presses a button on the applicator touch pad
- When a treatment begins
- When the system detects an error
- When a treatment ends

Control Unit - Rear View

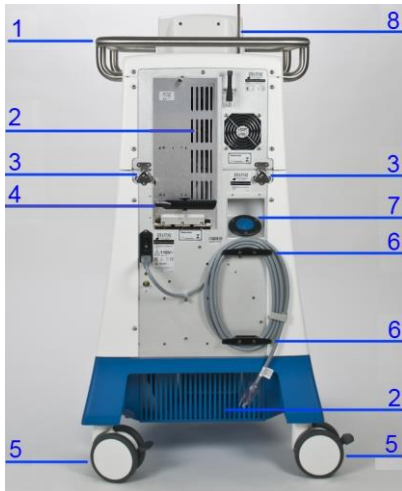

Components: Control Unit, Rear View

1. Rail: When the applicator is resting on top of the control unit, the rail helps keep the applicator in place. In addition, the rail is used as a handle to move the system.
2. Vents: Vents provide airflow that reduces heat build-up inside the control unit. Ensure that all vents are free from obstructions when the control unit is in operation.
3. Latches: The latches lock the upper and lower modules of the control unit together.
4. Antenna: The antenna and data modem send data to ZELTIQ. (Availability and use of the data modem are subject to regional limitations.)
5. Casters and locks: The control unit has four casters that swivel. Each caster has a lock. Always engage the locks on all four casters before you use the control unit.
6. Cleats: When the power cord is not in use, wrap it loosely around the cleats.
7. Chiller tank cap: The chiller tank cap provides access to the chiller tank for checking the coolant level and adding coolant.
8. Support Arm: Drape the applicator cable over the support arm to minimize drag on the connections and to keep the cable out of your way. Use the Velcro® straps to secure the cable to the support arm.

Power Cord Clamp

The power cord clamp attaches the power cord to the rear of the control unit. Install the power cord clamp before using the system. If the power cord is dislodged during a treatment, the treatment will be ended abruptly.

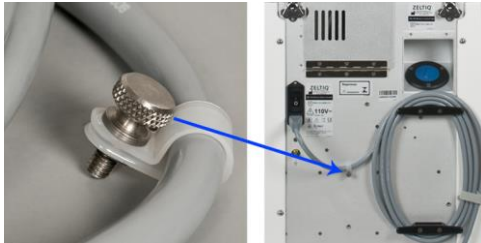

► **To install the power cord clamp:**

1. Insert the thumbscrew into the hole on the rear of the control unit.
2. Using your fingers, turn the thumbscrew until it is snug.

Power Switch and Power Receptacle

The power switch controls power to the control unit and system components. The power receptacle houses the plug for the power cord.



Components

1. Power Switch
2. Power Receptacle

► **To power on the control unit:**

1. Insert one end of the power cord into the power receptacle.
2. Insert the other end of the power cord into a grounded wall outlet.
3. Press the power switch on the back of the control unit to the On position.
4. The control unit powers on and displays the first screen.

Potential Equalization Test Connector

The test connector is for use by trained personnel only.

Access Panel

► **To open the access panel cover:**

1. Turn the thumb screw on the cover counterclockwise until it is loose.



- Open the cover downward.

The block holds the cover in a perpendicular position.

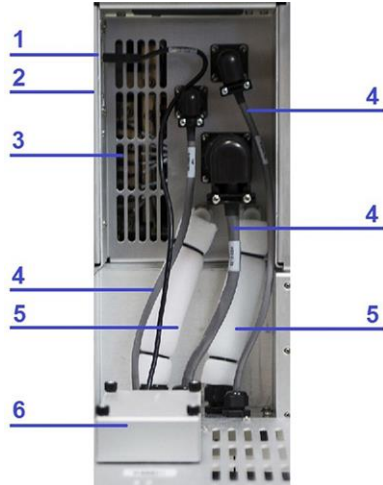

Components: Access Panel

- Upper Port: The upper USB port (rectangular) is intended for use with approved software and hardware provided by ZELTIQ.
- Lower Port: The lower USB port (square) is for use by ZELTIQ Customer Service personnel. Do not use the service port.
- Vents: Vents provide airflow that reduces heat build-up inside the control unit. Ensure that all vents are free from obstructions when the control unit is in operation.
- Cables: The cables connect the upper module to the base module and carry electrical information between the two modules.
- Hoses: The hoses connect the upper module to the base module and carry coolant between the two modules.
- Data Modem: The antenna and data modem send data to ZELTIQ. (Availability and use of the data modem are subject to regional limitations.)

Moving the Control Unit

► *To move the control unit:*

- Power off the control unit.
- Unplug the power cord from the wall outlet.
- Wrap the power cord around the cleats on the back of the control unit.
Ensure that the cord does not exert force on the power cord clamp.
- Release the locks on the casters.
- Push or pull the rail to move the control unit to the new location.
- Engage the locks on all four casters.

Applicators

CAUTION: Always use foam borders, gelpads, gel, liners, and securement systems with the applicator as instructed in the directions for use.

The applicator delivers controlled cooling and warming to the treatment site; the vacuum applicator can deliver optional massage to the treatment site.

The applicator consists of the applicator connector, the applicator cable, and the applicator head. The applicator is used with supplies provided by ZELTIQ.

For information about using the applicator in a treatment, see:

- Attach the Applicator to the Control Unit on page 24
- Surface Applicator Treatment on page 29
- Vacuum Applicator Treatment on page 28
- CoolAdvantage Directions for Use
- CoolMini Directions for Use

Supplies

Card

The card provides cycles and profiles for use with the system. Each cycle provides a single treatment. The profiles define the number of timed segments of cooling and warming. The profiles for a vacuum applicator may include massage segments.

- Elements of a Profile on page 23
- Insert a Card on page 26
- Select a Profile on page 27

Coolant

The control unit requires an adequate supply of ZELTIQ coolant. When the coolant level is low, a **Recoverable Exception** message is displayed.

Foam Borders

Foam borders minimize movement of the surface applicator during treatment. Refer to the directions for use for foam borders.

Gasket

(CoolAdvantage Applicators)

The gasket provides a tight seal between the CoolAdvantage applicator cup and the contour.

Gel

CoolSculpting gel provides thermal contact between the applicator and the patient's skin. The gel is intended for a single use only. Refer to the gel or applicator directions for use for safety information on using gel.

Gelpad

The gelpad provides thermal contact between the applicator and the patient's skin. The gelpad is intended for a single use only. Refer to the gelpad directions for use for safety information on selecting and using gelpads.

Gel Trap

(CoolAdvantage and CoolMini Applicators)

The gel trap fits into the slot in the bottom of the applicator cup. The gel trap prevents the ingress of gel into the vacuum system. Use a new gel trap for each treatment.

Liner

The liner provides a clean surface between the patient and the applicator and minimizes the spread of gel from the gelpad. Refer to the liner directions for use for information on selecting and using liners.

Pretreatment Skin Wipe

Use the Pretreatment Skin Wipe (skin wipe) to prepare the treatment site before applying a gelpad. See Surface Applicator Treatment on page 29.

Securement System

The securement system comprises a center panel and four straps. The securement system minimizes movement of the surface applicator during treatment. Refer to the securement system directions for use.

CHAPTER 2

TREATMENT

Contents

- Overview..... 23
- Perform a Treatment..... 23
- Perform Another Treatment..... 31
- Cancel a Treatment..... 33
- About Restarting a Treatment..... 34
- Complete a Treatment..... 35

Overview

A treatment is comprised of timed segments of cooling and heating; a vacuum treatment may include optional massage. Each treatment is based on a profile, which is contained on the card. Each card contains a set number of cycles and a list of profiles. When all the cycles have been used, the card is expired.

About Profiles

The profile defines the temperature and duration of a treatment. The surface applicator cools tissue from one side and the vacuum applicator cools tissue from two sides; therefore, the rate of heat extraction and the intensity of cooling achieved during a given period of time are greater with a vacuum applicator than with a surface applicator. However, the total heat extraction for a given treatment is a function of temperature and time, regardless of the applicator type.

Elements of a Profile

A profile contains the following elements:

Element	Description
°C	The treatment temperature.
Time	The duration of the treatment.
Massage	(Vacuum applicator only) Massage segment: Yes or No.

Table 12: Elements of a Profile

Perform a Treatment

- Set up the Control Unit on page 24
- Attach the Applicator to the Control Unit on page 24
- Insert a Card on page 26
- Enter Patient Data on page 26
- Select a Profile on page 27
- Vacuum Applicator Treatment on page 28
- Surface Applicator Treatment on page 29

Set up the Control Unit

► *To set up the control unit:*

1. Position the control unit next to the bed or chair to be used for the treatment.
2. Ensure that the vents on all four sides of the system have adequate ventilation.
3. Ensure that the operator can access the power switch easily.
4. Insert the power plug into a grounded outlet.

WARNING: To minimize the risk of electric shock, connect this equipment to a grounded electrical outlet.

5. Engage the locks on all four casters.
 6. Power on the control unit.
- The Applicator? and Card? cues are displayed on the Startup screen.



Attach the Applicator to the Control Unit

These examples show a vacuum applicator.

► *To attach the applicator to the control unit:*

1. Ensure that the support arm is installed on the side of the control unit that will be next to the treatment bed or chair.
To install the support arm, insert the straight end into the jack.
2. Place the applicator on top of the control unit.
3. Position the connector above the connector plate.

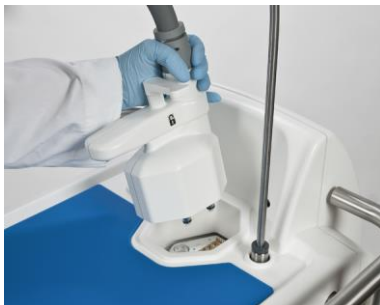

4. With the locking lever in the Unlocked position, press the applicator connector down onto the connector plate gently but firmly.



5. When the connector meets resistance, stop pressing down.
6. Turn the locking handle 180° clockwise to the Locked position. The connector is pulled into the connector plate and locked in place.
7. Slip the applicator cable into the loop at the top of the support arm.
8. Apply Velcro® straps to connect the applicator cable to the support arm.



The applicator is authenticated.

When the process is complete, the authentication confirmation and the Card? cue are displayed in the middle of the screen.

The name of the applicator is displayed in the lower left corner.

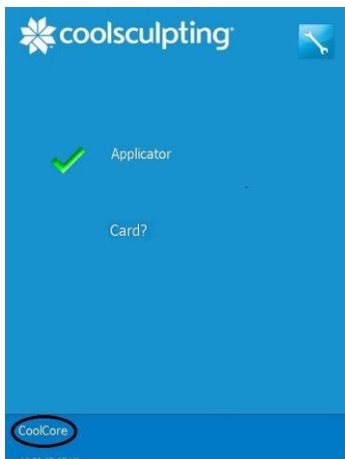

In this example, the applicator name is **CoolCore**.

Note: For information about status lights and touch pad controls, refer to the directions for use for your applicator.

Insert a Card

► **To insert a card:**

1. Align the card to the slot on the applicator.

Note: For CoolAdvantage and CoolMini applicators, insert the card into the slot on the applicator adapter.

2. Insert the card into the slot.

The card is authenticated.

The authentication confirmation and the number of cycles remaining on the card are displayed in the middle of the screen.

The name of the card and the number of cycles remaining are displayed in the lower right corner.

The Next button is displayed.

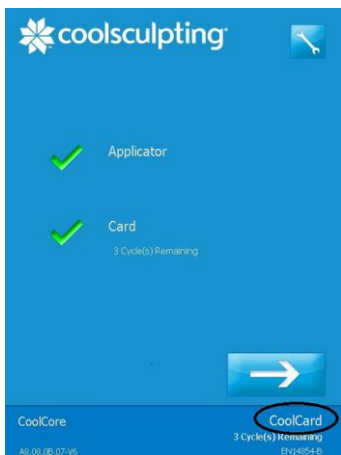

In this example, the name of the card is **CoolCard**.

3. Press the Next button.



The New to Practice and Returning to Practice buttons are displayed.



Note: If the patient data controls are not displayed, contact Customer Service.

Enter Patient Data

Note: If the Usage Metrics function has been disabled, the Profile panel is displayed. See Select a Profile on page 27.

► **To enter patient data:**

1. Press the New to Practice or Returning to Practice button.



2. Press the Female Patient or Male Patient button.



3. On the Body Profile screen, select a treatment site.

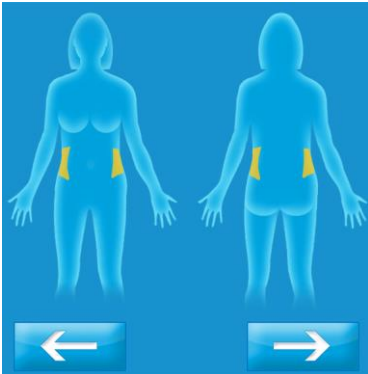

In this example, the flanks are selected for a female patient.



Refer to the Preface for warnings and cleared intended use.

4. Press the Next button.



5. Press the appropriate button for the current patient and treatment site.
6. The Profile panel is displayed.

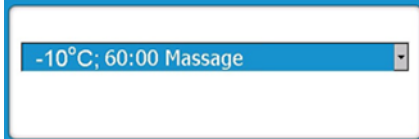

In this example, a vacuum applicator profile is displayed.

Select a Profile

► To select a profile:

1. On the profile panel, press the Display Profiles button.



The drop-down list of available profiles is displayed.

The default profile is selected.

This example shows vacuum applicator profiles.



2. Press the desired profile.
The drop-down list is hidden and the selected profile is displayed.
3. Press the Next button.



Vacuum Applicator Treatment

- For a CoolAdvantage treatment, see the CoolAdvantage Directions for Use.
- For a CoolMini treatment, see the CoolMini Directions for Use.

If a liner is detected, the GELPAD? button is displayed.



If no liner is detected, the Liner? cue is displayed.



1. Install a liner.

CAUTION: Use a new liner on each patient.

CAUTION: Refer to the directions for use for your liner.

When the system detects the liner, it displays the GELPAD? button.



Note: If the liner is not detected, disconnect the tabs from the hooks. Grasp the frames of the liner and remove the liner from the applicator cup. Repeat the installation process.

► **To apply a gelpad:**

WARNING: Inspect the treatment site to ensure that the skin is intact. Treat over intact skin only.

1. Remove jewelry that is in or directly adjacent to the application site.
2. Wipe the treatment site with an alcohol wipe and/or pretreatment skin wipe.

WARNING: Refer to the directions for use for your gelpad.

3. Press the GELPAD? button.



4. On the Gelpad Ready screen, press the Next button.



The Vacuum panel is displayed.



The Vacuum cue on the lower right spins.

The Vacuum Status light on the applicator touch pad flashes blue.

► **To apply a vacuum applicator:**

WARNING: The use of this device on areas with superficially located nerve branches, arteries, or veins has not been demonstrated to be safe and effective. Such use may result in injury to the patient.

WARNING: If the gelpad slips and the cooling surfaces of the applicator come into direct contact with the patient’s skin, tissue injury may result. Inspect the gelpad and applicator to ensure that the gelpad extends beyond the edges of the applicator cup.

Note: Use the default vacuum settings or the lowest settings that result in acceptable tissue draw into the applicator cup.

1. Press the Vacuum On/Off button on the applicator touch pad.



The vacuum is activated.

The Vacuum On button and the Tissue Draw indicator are displayed.

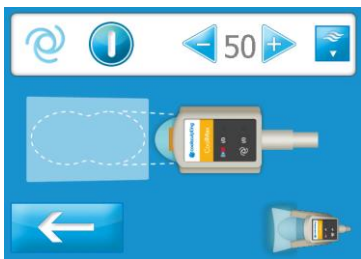

The Vacuum Status light on the applicator touch pad shines blue.

2. Place the applicator over the center of the gelpad on the treatment site.
3. Ensure that the gelpad extends beyond the edges of the applicator cup.
4. For best results, ensure that tissue is drawn into the applicator cup.
5. (Optional: Test Vacuum Pressure for Massage)
6. When the system detects that the applicator is connected to the treatment site, the Start button is displayed.



The Treatment Status light on the applicator touch pad flashes blue.

Press the Start button.



The Treatment Status light on the applicator touch pad shines blue.

Surface Applicator Treatment

The CONFIRM? Site Preparation button is displayed.



WARNING: Inspect the treatment site to ensure that the skin is intact. Treat over intact skin only.

1. Remove jewelry that is in or directly adjacent to the treatment site.

CAUTION: Prepare the treatment site with an alcohol wipe.

2. Apply one pair of foam borders around the treatment site.

CAUTION: Refer to the directions for use for your foam borders.

3. Wipe the treatment site with a pretreatment skin wipe.
4. Apply a gelpad to the treatment site.

WARNING: Refer to the directions for use for your gelpad.

5. Apply a liner over the gelpad.

CAUTION: Refer to the directions for use for your liner.

6. Press the CONFIRM? Site Preparation button.



7. Press the Next button.



The Surface Applicator Placement Cue is displayed.



► **To apply a surface applicator:**

WARNING: The use of this device on areas with superficially located nerve branches, arteries, or veins has not been demonstrated to be safe and effective. Such use may result in injury to the patient.

WARNING: If the gelpad slips and the cooling surfaces of the applicator come into direct contact with the patient's skin, tissue injury may result. Inspect the gelpad and liner to ensure that they extend beyond the outside edges of the foam borders.

1. Place the applicator between the foam borders on the treatment site.
2. Ensure that the gelpad and liner extend beyond the outside edges of the foam borders.
3. Wrap the securement system straps around the patient to secure the applicator in place.

Note: Refer to the securement system directions for use for information on securing the applicator in place.

4. Press the Start button.



The Treatment Status light on the applicator shines blue.

Perform Another Treatment

► *To perform another treatment on the same patient:*

CAUTION: When the vacuum is turned off or the securement system straps are released, the applicator may disengage from the patient. The applicator could fall and be damaged or cause injury. Grasp the head of the applicator firmly before turning off the vacuum or releasing the securement system straps.

Remove a vacuum applicator:	Remove a surface applicator:
Grasp the applicator and turn off the vacuum.	Grasp the applicator and release the securement system straps.
Remove the applicator from the patient.	Remove the applicator from the patient.
Place the applicator head on top of the control unit with the cooling surfaces facing downward.	Place the applicator head on top of the control unit with the cooling surfaces facing upward.
Allow gel to drain onto a towel or other absorbent material.	n/a
Remove the gelpad or gel from the treatment site.	Remove the liner, gelpad, and foam borders from the treatment site.
Discard the used gelpad or gel according to your site’s medical waste protocols.	Discard the used liner, gelpad, and foam borders according to your site’s medical waste protocols.

The Same Patient and Next Patient buttons are displayed.



(If the card is expired, see Expired Card on page 32.)

1. Press the Same Patient button.



2. On the Body Profile screen, select a treatment site.

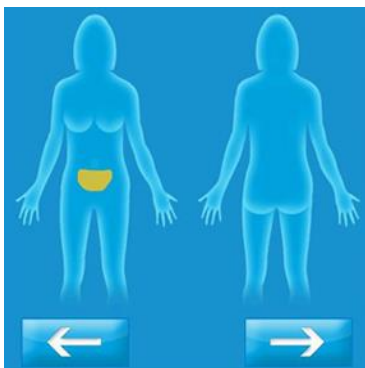

In this example, the lower abdomen is selected for a female patient.



Refer to the Preface for warnings and cleared intended use.

3. Press the Next button.



4. Press the appropriate button for the current patient and treatment site.

The Profile panel is displayed.

- See Select a Profile on page 27.

► **To perform a treatment on the next patient:**

CAUTION: When the vacuum is turned off or the securement system straps are released, the applicator may disengage from the patient. The applicator could fall and be damaged or cause injury. Grasp the head of the applicator firmly before turning off the vacuum or releasing the securement system straps.

Remove a vacuum applicator:	Remove a surface applicator:
Grasp the applicator and turn off the vacuum.	Grasp the applicator and release the securement system straps.
Remove the applicator from the patient.	Remove the applicator from the patient.
Place the applicator head on top of the control unit with the cooling surfaces facing downward.	Place the applicator head on top of the control unit with the cooling surfaces facing upward.
Allow gel to drain onto a towel or other absorbent material.	n/a
Remove the gelpad or gel from the treatment site.	Remove the liner, gelpad, and foam borders from the treatment site.
Remove the liner from the applicator cup.	n/a
Discard the used gelpad or gel, and liner according to your site's medical waste protocols.	Discard the used liner, gelpad, foam borders, and securement system according to your site's medical waste protocols.

1. If the Same Patient and Next Patient buttons are displayed, press the Next Patient button.



If the Profile panel is displayed, select a profile.

- See Enter Patient Data on page 26.

Expired Card

If the card is expired, a recoverable exception is displayed.

1. Remove the card from the applicator.
2. Press the Next button to clear the message.



3. Insert a new card into the slot on the applicator.

The system authenticates the card.

4. When authentication is complete, press the Next button.



The Profile screen is displayed.

Cancel a Treatment

A treatment can be canceled by the system or by the operator.

► *To cancel a treatment in the first 10 minutes:*

1. Press the Interrupt button.



2. Press the Cancel button.



3. Press the YES button.

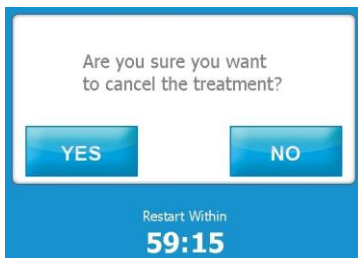

The treatment is canceled and a message is displayed:

“The treatment was canceled by the operator.”

4. Press the Next button.



► *To cancel a treatment after the first 10 minutes:*

1. Press the Cancel button.



The treatment is canceled and a message is displayed.

“The treatment was canceled by the operator.”

2. Press the Next button.



Note: The Warming cue may be displayed for up to 2 minutes. When the applicator cup is ready for the next treatment, the Next button is displayed.

About Restarting a Treatment

A treatment can be interrupted by either the operator or the system. When you restart a treatment, the treatment count on the card is not reduced further.

Each treatment can be restarted only once.

A treatment can be restarted if:

- The operator interrupted the treatment during the first 10 minutes
- The system interrupted the treatment during the first 10 minutes with one of the following Recoverable Exceptions:
 - The coolant level is low. Z403-YYY
 - Applicator control error. Z408-YYY
 - Treatment quality error. Z412-YYY
 - Potential loss of patient contact. Z415-YYY
 - Interference detected. Z426-YYY
- And, the Restart timer interval of 60 minutes has not expired

Interrupt a Treatment

► *To interrupt a treatment:*

1. Press the Interrupt button.



The Treatment Interrupted screen is displayed.



The Restart Timer runs for up to 60 minutes, after which the treatment can no longer be restarted.

2. Press the Next button to continue.



Note: The Warming cue may be displayed for up to 2 minutes. When the applicator cup is ready for the next treatment, the Next button is displayed.

Restart a Treatment

CAUTION: When the vacuum is turned off or the securement system straps are released, the applicator may disengage from the patient. The applicator could fall and be damaged or cause injury. Grasp the head of the applicator firmly before turning off the vacuum or releasing the securement system straps.

Note: The patient data that was used to start the treatment will be used to complete the treatment.

► To restart a treatment:

Remove a vacuum applicator:	Remove a surface applicator:
Grasp the applicator and turn off the vacuum.	Grasp the applicator and release the securement system straps.
Remove the applicator from the patient.	Remove the applicator from the patient.
Place the applicator head on top of the control unit with the cooling surfaces facing downward.	Place the applicator head on top of the control unit with the cooling surfaces facing upward.
Allow gel to drain onto a towel or other absorbent material.	n/a
Remove the gelpad or gel from the treatment site.	Remove the liner and gelpad from the treatment site.
Discard the used gelpad or gel according to your site's medical waste protocols.	Discard the used liner and gelpad according to your site's medical waste protocols.

- See Vacuum Applicator Treatment on page 28
- See Surface Applicator Treatment on page 29

Complete a Treatment

► To complete a treatment:

When the treatment is complete, a message is displayed.

“The treatment is complete.”

CAUTION: When the vacuum is turned off or the securement system straps are released, the applicator may disengage from the patient. The applicator could fall and be damaged or cause injury. Grasp the head of the applicator firmly before turning off the vacuum or releasing the securement system straps.

Remove a vacuum applicator:	Remove a surface applicator:
Grasp the applicator and turn off the vacuum.	Grasp the applicator and release the securement system straps.
Remove the applicator from the patient.	Remove the applicator from the patient.
Place the applicator head on top of the control unit with the cooling surfaces facing downward.	Place the applicator head on top of the control unit with the cooling surfaces facing upward.
Allow gel to drain onto a towel or other absorbent material.	n/a

Remove a vacuum applicator:	Remove a surface applicator:
Remove the gelpad or gel from the treatment site.	Remove the liner, gelpad, and foam borders from the treatment site.
Remove the liner from the applicator cup.	n/a
Discard the used gelpad or gel, and liner according to your site's medical waste protocols.	Discard the used liner, gelpad, foam borders, and securement system according to your site's medical waste protocols.

1. Wipe gel from the patient's skin.
2. Wipe the cooling surfaces of the applicator with a soft, dry cloth.
3. To power off the control unit, press the power switch.

CAUTION: The electronic sensors on the cooling surfaces of the applicator are delicate. Use care when cleaning and storing the applicator. (See Cleaning on page 39.)

Test Vacuum Pressure for Massage

(Standard vacuum applicators only) Before you start a treatment, you can test and modify the vacuum pressure for massage to ensure that the vacuum pressure is high enough to keep the applicator in place during the treatment.

► **To test the vacuum pressure for massage:**

1. When the applicator is on the treatment site and the tissue is drawn into the applicator cup, press the Display Massage Settings button.



The Message Settings Panel is displayed.

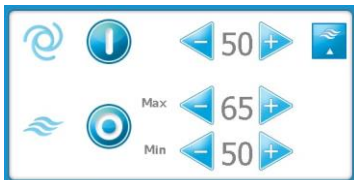

2. Press the Message Status (Off) button on the Message Settings panel.



3. Press the Max and Min Increase and Decrease buttons on the Message Settings panel if needed to modify vacuum pressure for massage.
4. Press the Message Status (On) button to turn off massage.



5. Press the Hide Message Settings button.



6. If necessary, adjust the position of the vacuum applicator and modify the vacuum pressure for massage.
7. If you turn off the vacuum and then remove the vacuum applicator from the site:
 - a) Discard the used gelpad or gel according to your site's medical waste protocols.
 - b) Clean the treatment site.
 - c) Apply a new gelpad or new gel. (Refer to the Directions for Use for your gelpad. See page 27.)

CHAPTER 3

CLEANING AND MAINTENANCE

Contents

- Cleaning 39
- Maintenance..... 40
- Disassembling the Control Unit 43
- Assembling the Control Unit..... 46
- Connecting Latches, Hoses, and Cables..... 47
- Customer Service 48

Perform routine cleaning and maintenance according to your site's protocols.

Cleaning

CAUTION: The use of an unapproved cleaning solution or method on the control unit or applicator may result in damage. Always use approved products and follow the guidelines below.

Approved Products

The following products are approved for cleaning the control unit and applicators:

- Isopropyl alcohol
- Mild detergent and warm water
- PDI Sani Cloth Plus wipes

Cleaning Guidelines

- Unplug the control unit before cleaning.
- Use sterilization wipes or spray the cleaning agent on a soft wipe, paper towel, or equivalent material.

CAUTION: Do not spray or spill any fluid directly on any part of the control unit, applicators, or supplies.

CAUTION: Do not submerge the applicator or any other part of the system in any liquid.

- Do not use excessive amounts of fluid.
- Do not apply cleaning solution to the electrical connections.
- After cleaning the system components, dry them with a soft cloth to remove any cleaning residues.
- Do not sterilize the control unit, applicator, or any other system components.

Cleaning the Touch Screen

For best performance, clean the touch screen regularly.

Approved cleaning products include:

- Isopropyl alcohol
- Window cleaning fluid

► **To clean the touch screen:**

1. Dampen a soft lint-free cloth with isopropyl alcohol or a window cleaning fluid.
2. Wipe the touch screen gently.

Maintenance

External Chiller Filter

The CoolSculpting control unit has an external filter installed that is located on the front bottom of the system (Picture A) and is easily replaceable. The purpose of this filter is to extend the service life of your control unit.

► **Location of filter (Picture A):**



► **When to replace:**

Every 6 months or

Blue Thermometer icon appears for extended period of time:

3. (Picture B)



- 4.

The Z802-322 Chiller Pump alert message appears:

5. (Picture C)



► **How to replace the external chiller filter:**

Turn the control unit off prior to replacing the filter

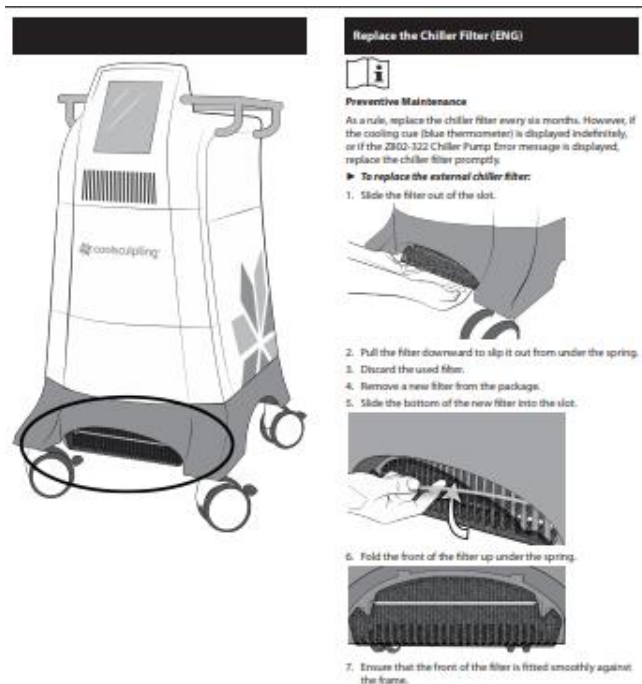

► **How to order:**

The replacement part number is FRU-CTU-BAM-103 and can be ordered by contacting your local Allergan office.

Coolant

Coolant circulates between the control unit and the applicator to remove heat from the applicator. When you connect a new applicator, it takes up a significant amount of coolant. Also, when you disconnect an applicator, or disconnect the hoses on the access panel to prepare for shipping a module, a small amount of coolant may be lost.

When the level of coolant is low, the control unit displays a message. It is safe to add coolant while the control unit is powered on.

CAUTION: The use of unauthorized coolant has not been tested. Always use coolant authorized by ZELTIQ.

► **To add coolant:**

1. Locate the chiller tank cap.

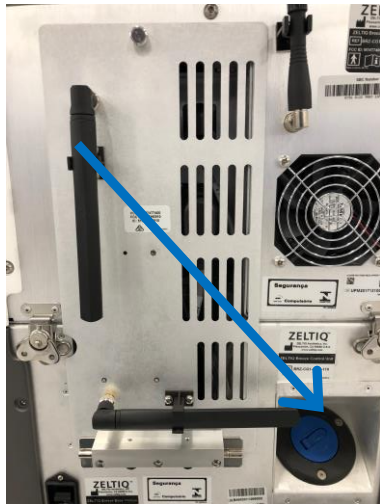

2. Press down on the recessed end of the blue lever on the chiller tank cap.



The handle flips up.



3. Turn the blue handle counter-clockwise until the cap disengages.
4. Remove the cap.
5. Pour coolant into the tank.

The amount of additional coolant that is required can vary. To avoid spillage, watch the coolant as you pour. Listen for changes in the sound.

6. Replace the cap and tighten it just until snug.

When the vacuum is activated, it pulls the cap in tighter. If you overtighten the cap, it could become too tight to loosen.

Disassembling the Control Unit

The control unit consists of an upper module and a base module. Disassemble the control unit to prepare to ship either module to the factory for repair or replacement.

CAUTION: The upper and base modules of the control unit are heavy. Do not attempt to lift either module by yourself. This procedure requires two people.

Latches

► **To disassemble the control unit:**

1. Power off the control unit.
2. Engage the locks on all four casters.
3. Disconnect the power cord from the control unit.
4. Wrap the power cord around the cleats and secure it with the Velcro® strap.
5. Open the storage drawer and disconnect the latches on the front of the control unit.



6. Disconnect the latches on the back of the control unit.



► **To disconnect a latch:**

1. Flip the handle of the latch upward and turn it counterclockwise until the top of the clasp disengages.



2. Pull the handle back and let it hang downward.



Cables and Hoses

► **To disconnect cables and hoses:**

1. Turn the thumbscrew on the cover of the access panel.



2. Let the cover hang down, exposing the cables and hoses.



3. Working from left to right, disconnect the cables and then the hoses.

► **To disconnect the data modem cable:**

If the data modem cable is disconnected, skip this step.

1. Grasp the head of the data modem cable.
2. Pull the head straight out of the USB port.

► **To disconnect a cable:**

1. Locate the ring that is closest to the back of the access panel.
2. Turn the ring counterclockwise until it moves freely.
3. Pull the ring off the connector.

► **To disconnect a hose:**

1. Squeeze the metal clasp at the top of the hose connector.



2. Pull back until the hose connector disengages from the jack.

Note: A small amount of coolant may drip from the hoses. Wipe up coolant with a soft cloth.

Remove Upper Module

► **To remove the upper module:**

1. Engage the locks on all four casters.
2. Prepare a place to put the upper module.
3. Position each person on one side of the control unit.
4. Have each person grasp the rail with two hands.
5. Lift the upper module.



6. Walk past the base module and put the upper module down.

Assembling the Control Unit

CAUTION: The upper and base modules of the control unit are heavy. Do not attempt to lift either module by yourself. This procedure requires two people.

► **To install the upper module:**

1. Engage the locks on all four casters.
2. Ensure that the power cord is disconnected from the control unit.
3. Ensure that the cables and hoses that are attached to the base module are out of the way.
4. Place the base module in front of the upper module.
5. Grasp the bar on the upper module and lift the upper module into position on top of the base module.



6. Ensure that the cables and hoses are clear.



7. Connect the latches, cables, and hoses.
8. Ensure that the upper module is aligned to the base module.



Connecting Latches, Hoses, and Cables

► *To connect a latch:*

1. Place the top clasp over the top hook.
2. Flip the handle of the latch outward.
3. Turn the handle clockwise until the top clasp is snug against the hook.
4. Press the handle down.

► *To connect the hoses and cables:*

1. Start with the hose on the right.
2. Press the hose into the jack.
3. Repeat for the hose on the left.
4. Press the cable connector on the right over the post.
5. Turn the ring clockwise until it is snug. Do not overtighten.
6. Repeat for the remaining cables, working from right to left.
7. Close the cover of the access panel.
8. Align the thumbscrew on the cover of the access panel to the hole on the upper module.



9. Turn the thumbscrew to the right just until it is snug. Do not overtighten.

► **To connect the data modem cable:**

1. Grasp the head of the data modem cable.
2. Ensure that the USB symbol is facing upward.
3. Insert the head of the cable into the upper USB port.

Customer Service

To report issues with the performance or use of your System, contact ZELTIQ Customer Service.

- Worldwide: (+1) 925-474-8160
- United States: 1-888-935-8471 (1-888-ZELTIQ1)

Routine Issues

For questions regarding device performance or to report issues that do not interfere with current patient treatments:

- Call during regular business hours, 6 am to 6 pm, Pacific Time, Monday through Friday. Calls are answered in the order received.

Urgent Issues

To report safety concerns or issues that interfere with current patient treatments:

- Call at any time. Outside regular business hours (above), leave a voicemail. A technician will be paged and will return your call promptly.

APPENDIX A

SYSTEM MESSAGES

Contents

- ZELTIQ Customer Service 49
- Recoverable Exceptions..... 49
- Error Messages 51
- General Messages..... 51
- Software Updates and Messages 52

This appendix lists system messages with the suggested user action, if any. Each message includes a message code that is preceded by the letter Z and a Customer Service code.

Carry out the recommended action, if any. If the problem persists, record both codes and call Customer Service. Customer Service will use the codes in order to help resolve the issue. For assistance with any message not listed here, call Customer Service.

ZELTIQ Customer Service

- Worldwide: (+1) 925-474-8160
- United States: 1-888-935-8471 (1-888-ZELTIQ1)

Recoverable Exceptions

Message	Action
Applicator error. Z401-YYY Disconnect and reconnect the applicator.	Disconnect and reconnect the applicator.
The card expired. Z402-YYY Connect a new card.	Remove the card from the applicator and insert a new card.
The coolant level is low. Z403-YYY Add coolant.	Add coolant.
The card and applicator are incompatible. Z404-YYY	Remove the card from the applicator. Insert a card that is appropriate for the applicator type.
Applicator software error. Z405-YYY Replace the applicator.	Use another applicator.
Card error. Z406-YYY Disconnect and reconnect the card.	Remove and reinsert the card.
Card error. Z407-YYY Disconnect and reconnect the card.	Remove and reinsert the card.
Applicator control error. Z408-YYY Start a treatment. If the problem persists, call Customer Service.	Start a treatment. If the problem persists, replace the applicator.

Message	Action
<p>CAUTION</p> <p>Thermal event detected. Z409-YYY</p> <p>Remove the applicator and gelpad. Refer to the user manual.</p>	<p>CoolAdvantage and CoolMini applicators:</p> <ul style="list-style-type: none"> Do not retreat for at least 24 hours. <p>All other applicators:</p> <ul style="list-style-type: none"> If you receive a second Z409 for a single treatment site, discontinue treatment for the site, do not retreat for at least 24 hours.
<p>Applicator control error. Z410-YYY</p> <p>Start a treatment. If the problem persists, call Customer Service.</p>	<p>Start a treatment. If the problem persists, call Customer Service.</p>
<p>Applicator error. Z411-YYY</p> <p>Power the control unit off and on.</p>	<p>Power the control unit off and on.</p>
<p>Treatment quality error. Z412-YYY</p> <p>Start a treatment. If the problem persists, call Customer Service.</p>	<p>Restart the treatment or start a new treatment.</p>
<p>Applicator error. Z414-YYY</p> <p>Disconnect and reconnect the applicator.</p>	<p>Disconnect and reconnect the applicator.</p>
<p>Potential loss of patient contact. Z415-YYY</p> <p>Reapply the applicator and start a treatment. If the problem persists, call Customer Service.</p>	<p>Turn off the vacuum, remove the applicator cup from the patient, discard the used gelpad or gel, clean the treatment site, and apply a new gelpad or new gel. Restart an interrupted treatment or start a new treatment.</p>
<p>Card compatibility error. Z417-YYY</p> <p>Replace the card.</p>	<p>Insert a card that is compatible with the control unit.</p>
<p>Card compatibility error. Z418-YYY</p> <p>Call Customer Service.</p>	<p>Call Customer Service.</p>
<p>Card compatibility error. Z420-YYY</p> <p>Call Customer Service.</p>	<p>Call Customer Service.</p>
<p>Card error. Z421-YYY</p> <p>Disconnect and reconnect the card.</p>	<p>Disconnect and reconnect the card.</p>
<p>Disconnect and reconnect the applicator. Z422-YYY</p>	<p>Disconnect and reconnect the applicator.</p>
<p>The restart timer has expired. Z425-YYY</p> <p>Start a new treatment.</p>	<p>Start a new treatment.</p>
<p>Interference detected. Z426-YYY</p> <p>Start a treatment. If the problem persists, refer to the User Manual.</p>	<p>Identify and resolve possible causes:</p> <ul style="list-style-type: none"> Patient movement Another medical device in close proximity <p>If the problem persists, contact Customer Service.</p>
<p>This system must be serviced by ZELTIQ no later than YYYY-MM-DD to ensure continued use. Z428-YYY</p>	<p>Contact Customer Service.</p>
<p>The applicator adapter and applicator are incompatible. Z429-YYY. Contact Customer Service.</p>	<p>Contact Customer Service.</p>

Table 13: Recoverable Exceptions

Error Messages

For all system errors, power the control unit off and on. If the problem persists, call Customer Service. (ZELTIQ Customer Service on page 49)

Code	Message
Z801	Chiller error. Z801-YYY
Z802	Chiller error. Z802-YYY
Z803	Control unit error. Z803-YYY
Z804	Control unit error. Z804-YYY
Z805	Control unit error. Z805-YYY
Z806	Invalid configuration values. Z806-YYY
Z808	Software error. Z808-YYY
Z809	Control unit error. Z809-YYY
Z810	This system must be serviced by ZELTIQ. Contact Customer Service.
Z811	Control unit error. Z811-YYY
Z812	The device connected to the control unit is not recognized. Z812-YYY

Table 14: Error Messages

General Messages

Message	Recommended Action
The applicator is disconnected.	Connect the applicator to the control unit.
The card is disconnected.	Insert the card into the slot on the applicator. Ensure that the card is inserted correctly.
The treatment was canceled by the operator.	Restart the treatment or start a new treatment.
The treatment is complete.	Turn off vacuum, remove the applicator and gelpad or gel, and clean the treatment site.
The treatment was interrupted by the operator.	Restart the treatment or start a new treatment.
Turn off the vacuum. Remove the applicator and gelpad or gel.	Turn off vacuum power either on the applicator touch pad or on the system touch screen. Remove the applicator and gelpad or gel.
Are you sure you want to cancel the treatment?	Press the YES button to cancel the current treatment. Press the NO button to continue and restart the current treatment.

Table 15: General Messages

Software Updates and Messages

From time to time, ZELTIQ may provide software updates.







Button	Description	Name
	A software update is available.	Software Update
	Install the software update.	Install
	Clear the software update code.	Clear
	Delete the last character of the patient number.	Backspace
	Postpone the software update.	Postpone
	Start the update.	Next Update
	Skip the update.	Skip Update

Table 16: Controls and Cues for Software Updates

The following text and messages may be displayed.

Software Update Approximate installation time: xx minutes Installation must be performed no later than YYYY/MM/DD to ensure continued use.
Enter the Software Update Key.
Installation complete. Press the Next button.
Installation error. Z930 Power the control unit off and on. If the problem persists, contact Customer Service.
Installation error. Z961-YYY Remove the USB stick. Power the control unit off and on. Contact Customer Service.
Installation error. Z962-YYY Press the Next button. Contact Customer Service.
Installation error. Z963 Power the control unit off and on. If the problem persists, contact Customer Service.

Table 17: Software Update Installation Messages

CoolAdvantage Software Updates and Messages

In addition to the general software update messages, the following information may be displayed during a CoolAdvantage software update.

Software Update: Attach the applicator adapter to the control unit. Approximate installation time: xx minutes Installation must be performed no later than YYYY/MM/DD to ensure continued use.
Software updating
Installation complete. Press the Next button.
The applicator adapter was not detected. If you have an adapter, connect it to the control unit. To proceed with the update, press the Next button. To skip the update, press the Skip button.

Table 18: CoolAdvantage Software Update Installation Messages

APPENDIX B

SYSTEM TOOLS

Contents

- Controls for System Tools..... 55
- System Log Screen 55
- Card Log Screen 56
- Service Screen..... 58
- Settings Screen 60

This chapter describes the System Tools.

The System Tools button is available on the Startup screen, Profile screen, Recoverable Exception screen, and System Error screen.

Controls for System Tools





Button	Description	Name
	Display the System Tools screen.	System Tools
	Display the System Log screen to view information about system events.	System Log
	Display the Card Log screen to view usage history for the current card.	Card Log
	Display the Service screen to access the Vacuum Diagnostic and Chiller Diagnostic screens. (For use during a Customer Service call.)	Service
	Display the Settings screen to access the Calibration, Time Zone, and Date and Time screens.	Settings

Table 19: Controls for System Tools

System Log Screen

The System Log screen displays information about system events and errors.

Heading	Description
Date	The date of the event as Month, DD, YYYY.
Time	The time of the event as HH:MM where H = hour and M = minute.
Code	The ZELTIQ error code.
Condition	A description of the condition: Recoverable, System Error, Treatment Error.
Text	The text of the control unit message.

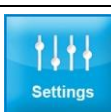
Table 20: System Log Headings

► **To view the System Log screen:**

1. On the System Tools screen, press the System Log button.



The System Log screen is displayed.

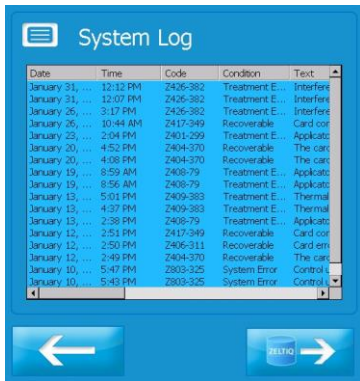

2. To scroll through the screen, drag the slider at the bottom or right side of the screen.
3. To return to the System Tools screen, press the Previous button.



Note: Availability and use of the data modem are subject to regional limitations. The Upload Data button is displayed only if the modem is activated.

Note: The data upload function is for use during a call with customer service.

► **To upload data to ZELTIQ:**

1. On the System Log screen, press the Upload Data button.



The Upload Status screen is displayed.

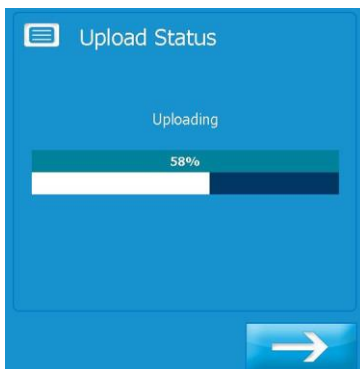

When the process is complete, a message is displayed:

Upload Status: Uploading, Upload complete, Upload failed

Card Log Screen

The Card Log screen displays information about card usage. View the Card Log screen when you have questions about the number of cycles remaining and when treatments were performed.

Heading	Description
Date	The date of the usage: Month, DD, YYYY.
Time	The time of the usage as HH:MM, where H = hour and M = minute, in AM/PM.
Status	The status of the usage: (Canceled, Error, Unknown, Successful)

Table 21: Card Log Headings

► **To view the Card Log screen:**

1. Attach the applicator to the control unit.
2. Insert the card into the slot on the applicator.
The control unit authenticates the card.
3. When the process is complete, press the Next button.



4. On the System Tools screen, press the Card Log button.
The Card Log screen is displayed.



5. To return to the System Tools screen, press the Previous button.



Service Screen

Controls for Service Tools

The tools on the Service screen are for use during a call with Customer Service. Follow the instructions provided by Customer Service.



Button	Description	Name
	Display the Vacuum Diagnostic screen to view information about the performance of the vacuum system.	Vacuum Diagnostic
	Display the Chiller Diagnostic screen to view information about the performance of the chiller.	Chiller Diagnostic
	The data modem can upload data to ZELTIQ. Availability and use of the data modem are subject to regional limitations.	Data Modem

Table 22: Controls for Service Tools

► **To view the Service screen:**

1. On the System Tools screen, press the Service button.



The Service screen is displayed.



Vacuum Diagnostic Screen

The Vacuum Diagnostic screen provides information about the performance of the vacuum system.

Any changes to settings on this screen are temporary and do not influence the functionality of the system during a treatment.

► **To view the Vacuum Diagnostic screen:**

1. On the Service screen, press the Vacuum Diagnostic button.



The Vacuum Diagnostic screen is displayed.

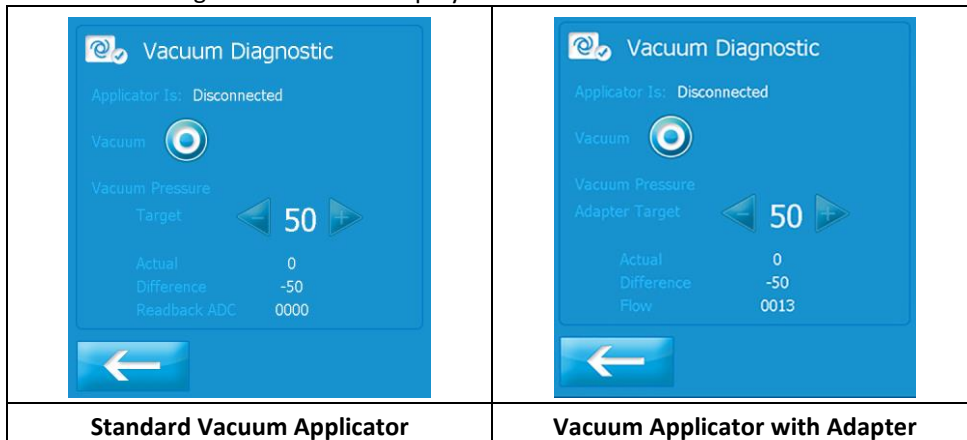

On the sample screens, the applicator is disconnected and vacuum power is off.

2. Follow the instructions provided by Customer Service.
3. To return to the System Tools screen, press the Previous button.



Chiller Diagnostic Screen

The Chiller Diagnostic screen provides information about the performance of the chiller.

Any changes to settings on this screen are temporary and do not influence the functionality of the system during a treatment.

► **To view the Chiller Diagnostic screen:**

1. On the Service screen, press the Chiller Diagnostic button.



The Chiller Diagnostic screen is displayed.



On the sample screen, the applicator is connected, the chiller is off, chiller power is off, and cooling is off.

2. Follow the instructions provided by Customer Service.
3. To return to the System Tools screen, press the Previous button.



Data Modem Screen

Availability and use of the data modem are subject to regional limitations. Contact customer service for further information.

► **To view the Data Modem screen:**

1. On the Service screen, press the Data Modem button.



The Data Modem screen is displayed.



On the sample screen, the Network Type is HSDPA_3G and the Connection Quality is Unknown.

2. Follow the instructions provided by Customer Service.
To return to the Service screen, press the Previous button.



Settings Screen

The Settings button is available on the System Tools screen.

Note: Ensure that the Time Zone setting is correct before you update the Date and Time settings.

Controls for Settings Tools

► **To view the Settings screen:**

1. On the System Tools screen, press the Settings button.



The Settings screen is displayed.

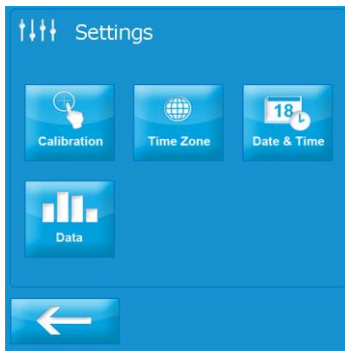

2. To return to the System Tools screen, press the Previous button.



Calibration Screen

The system screen might require recalibration from time to time. If the screen does not respond accurately to your touch, calibrate the screen.

► **To calibrate the screen:**

1. On the System Tools screen, press the Settings button.



2. Press the Calibration button.



The Calibration screen is displayed.

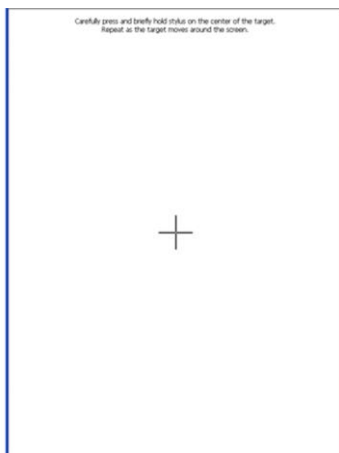

3. Use a cotton swab to press the cross-hatch.
The system records your touch and moves the cross-hatch to the next position.
4. Press the cross-hatch in each position.
After you press the last setting, the system displays a message.
5. To save your new settings, touch the screen within the time displayed in the message.

The new settings are saved and the Settings screen is displayed.

- To discard your new settings and retain the previous settings, wait until the time runs out, approximately 30 seconds.

The Settings screen is displayed.

Time Zone Screen

The setting on the Time Zone screen determines the time zone for entries on the Card Log screen and System Log screen.

Note: Always check the Date and Time settings after you modify the time zone.

► To modify the time zone:

- On the Settings screen, press the Time Zone button.



The Time Zone screen displays a list of regions.



- To select a region, press the name of the region and then press the Next button.



The Time Zone screen displays a list of zones within the region you selected.



- To scroll through the list, press and drag the scroll panel on the right.
- To select a time zone, press a row.
- To save changes, press the Next button.



- To discard changes, press the Cancel button.



- On the Settings screen, press the Date & Time button.



Date and Time Screen

Note: Ensure that the Time Zone setting is correct before you modify Date and Time settings.

► To modify date and time settings:

- On the Settings screen, press the Date & Time button.



The Date and Time screen is displayed.



- To modify settings, press the Decrease and Increase buttons.



- To save changes, press the Next button.



- To discard changes, press the Cancel button.



The Settings screen is displayed.

Note: The 24 Hour setting controls the hour of the day and is in a 24-hour format.

Data Screen

The Data screen displays the Usage Metrics button. The Usage Metrics button controls the display of patient data controls. The tools on the Data screen are for use during a call with Customer Service.

► **To view the Data screen:**

1. On the Settings screen, press the Data button.



2. The Data screen is displayed.

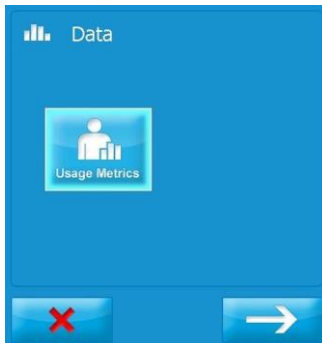

3. Follow the instructions provided by Customer Service.

APPENDIX C

SYSTEM SPECIFICATIONS

Contents

- Essential Performance 65
- Disposal of Hazardous Materials 65
- Environmental Requirements 65
- Electrical Specifications 66
- Medical Safety Standards 66
- Electromagnetic Compatibility 66
- Data Modem Specifications 70

This product may contain remanufactured parts or parts that have had incidental use, all of which are equivalent in performance to new parts.

Essential Performance

When cooling to a target temperature that is below 5°C, the device allows cooling to no more than 1°C below the target temperature. When warming to a target temperature that is above 30°C, the device allows warming to no more than 1°C above the target temperature. Under steady state conditions, the device controls vacuum pressure to within ± 1 inches of Hg.

Disposal of Hazardous Materials

Various components of the system may contain materials whose disposal is subject to regulation. The upper module of the system contains a lithium battery, which is not serviceable by the customer. Dispose of all components of the system in accordance with applicable regulations. Contact your local environmental control agency for additional information on recycling or disposing of the system in your area.

Environmental Requirements

The system and its components are designed to operate normally when stored, shipped, and operated under the following conditions.

WARNING: Use of the system in an oxygen-rich environment may cause fire. Do not use the system in an oxygen-rich environment.

CAUTION: The system may not operate as expected if it is stored or operated in conditions of excessive heat, humidity, or atmospheric pressure. Operate and store the system in a room that meets the stated requirements.

	Shipping / Storage	Operating
Temperature	32°F to 140°F (0°C - 60°C)	59°F to 82°F (15°C - 28°C)
Humidity	10% to 95% (non-condensing)	10% to 70% (non-condensing)
Atmospheric Pressure	Sea level to 10,000 feet at standard pressure	

Table 23: Shipping, Storage, and Operating Requirements

Dimensions of the Control Unit and Modules

	Height	Depth	Width	Weight
Control unit alone	47.5 in 120.7 cm	35 in 88.9 cm	24 in 61 cm	215 lbs 97.5 kg
Control unit with support arm	62 in 157.5 cm	n/a	n/a	216 lbs 98.0 kg
Upper module	17 in 43.2 cm	27.25 in 69.2 cm	21.25 in 54 cm	65 lbs 29.5 kg
Base module	30.5 in 77.5 cm	28.5 in 72.4 cm	24 in 61 cm	150 lbs 68.0 kg

Table 24: Control Unit - Dimensions

Electrical Specifications

Electrical Safety

Class I Equipment, single phase AC, Continuous Operation

Contains Type BF Patient-applied Parts

Water Ingress Protection: Ordinary Equipment, IPX0

REF	Voltage	Frequency	Current
BRZ-CG1-BAM-100	100VAC	50-60 Hz	12A
BRZ-CG1-BAM-110	110-120VAC	50-60 Hz	12A
BRZ-CG1-BAM-220	220-240VAC	50-60 Hz	7A

Table 25: Electrical Specifications

Fuses

The system contains two internal fuses: Type 3AB (ceramic cartridge), Rating: 250VAC, 6.25A, Slo-Blo. The fuses are not serviceable by the customer.

Medical Safety Standards

The system complies with the following medical safety standards:

- IEC 60601-1: 1998 + A1, A2
- IEC 60601-1: 2005 + CORR. 1 (2006) + CORR. 2 (2007)
- EN 60601-1: 2006
- CAN/CSA C22.2 No 60601.1: 08
- ANSI/AAMI ES 60601-1: 2005 / AS: 2010
- AS 3200.1.0: 1998 + A1/NZS 6150: 1990 + A1
- Electromagnetic Compatibility (EMC) EN 60601-1-2: 2007

Electromagnetic Compatibility

The system has been tested and found to comply with Medical Standard Electromagnetic Compatibility (EMC) EN 60601-1-2: 2007. The system complies with the standards outlined below.

This system requires special precautions to ensure electromagnetic compatibility with other electrical medical devices. To ensure EMC, the system must be installed and operated according to the information provided in this manual.

CAUTION: When the system is interconnected with other electrical devices, leakage currents may be additive, resulting in electromagnetic emissions that can interfere with the normal function of electronic medical equipment. To properly control electromagnetic emissions and avoid potential harm to the patient or user, ensure all electrical devices are installed and interconnected according to the requirements of IEC 60601-1-1.

CAUTION: Install the system in a room that complies with all applicable IEC, CEC, and NEC requirements for safety of electrical devices.

CAUTION: Portable and mobile RF communications equipment may affect the normal function of the system.

CAUTION: Use of the system adjacent to or stacked with other equipment may result in unexpected electromagnetic circumstances. Prior to such use, test the operation of the system in the proposed configuration and ensure it meets all requirements as defined in the tables below. Consult the tables below for guidance in placing the system.

CAUTION: Use ports on the system exactly as instructed in this manual. Any other use of these ports may cause unexpected results. See System Overview on page 11.

CAUTION: Do not use cables or accessories other than those provided by ZELTIQ. The use of other cables or accessories may result in increased electromagnetic emissions or decreased immunity to such emissions.

Guidance and Manufacturer’s Declaration -- Electromagnetic Emissions		
The system is intended for use in the electromagnetic environment specified below. The customer or user of the system should ensure that it is used in such an environment.		
Emissions Test	Compliance	Electromagnetic Environment - Guidance
RF Emissions CISPR 11	Group 1	The system uses RF energy only for its internal function; therefore, its RF emissions are very low and are not likely to cause any interference in nearby electronic equipment.
RF Emissions CISPR 11	Class A	(A) The system is suitable for use in all establishments other than domestic, and may be used in domestic establishments and those directly connected to the public low-voltage power supply network that supplies buildings used for domestic purposes, provided the following warning statement is heeded: CAUTION: The system is intended for use by healthcare professionals only. The system may cause radio interference or may disrupt the operation of nearby equipment. It may be necessary to take mitigation measures, such as reorienting or relocating the system or shielding the location.
Harmonic emissions IEC 61000-3-2	Class A	
Voltage fluctuations/ Flicker emissions IEC 61000-3-3	Class A	

Guidance and Manufacturer's Declaration -- Electromagnetic Immunity			
The system is intended for use in the electromagnetic environment specified below. The customer or user of the system should ensure that it is used in such an environment.			
Immunity Test	IEC 60601 Test Level	Compliance Level	Electromagnetic Environment - Guidance
Electrostatic discharge (ESD) IEC 61000-4-2	±6kV contact ±8kV air	±2,4,6kV contact ±2,4,8kV air	Floors should be wood, concrete, or ceramic tile. If floors are covered with synthetic material, the relative humidity should be at least 30%.
Electrical fast transient/burst IEC 61000-4-4	±2kV for power supply lines ±1kV for input/output lines	±2kV for line to ground ±1kV for line to line	Mains power quality should be that of a typical commercial or hospital environment.
Surge IEC 61000-4-5	±1kV differential mode ±2kV common mode	± 0.5, 1kV differential mode ±0.5, 1, 2kV common mode	Mains power quality should be that of a typical commercial or hospital environment.
Voltage dips, short interruptions, and voltage variations on power supply input lines IEC 61000-4-11	<5% U_T (>95% dip in U_T) for 0.5 cycle 40% U_T (60% dip in U_T) for 5 cycles 70% U_T (30% dip in U_T) for 25 cycles <5% U_T (>95% dip in U_T) for 5 sec	<5% U_T (>95% dip in U_T) for 0.5 cycle 40% U_T (60% dip in U_T) for 5 cycles 70% U_T (30% dip in U_T) for 25 cycles <5% U_T (>95% dip in U_T) for 5 sec	Mains power quality should be that of a typical commercial or hospital environment. If the user of the system requires continued operation during power mains interruptions, it is recommended that the system be powered from an uninterruptible power supply or a battery.
Power frequency (50/60Hz) magnetic field IEC 61000-4-8	3A/m	3A/m	Power frequency magnetic fields should be at levels characteristic of a typical location in a typical commercial or hospital environment.
NOTE: U_T is the AC mains voltage prior to application of the test level.			

Guidance and Manufacturer’s Declaration -- Electromagnetic Immunity			
The system is intended for use in the electromagnetic environment specified below. The customer or user of the system should ensure that it is used in such an environment.			
Immunity Test	IEC 60601 Test Level	Compliance Level	Electromagnetic Environment - Guidance
			Portable and mobile RF communications equipment should be used no closer to any part of the system, including its cables, than the recommended separation distance calculated from the equation applicable to the frequency of the transmitter.
			Recommended Separation Distance
Conducted RF IEC 61000-4-6	3 Vrms 150 kHz to 80 MHz	3 Vrms	$d = 1.17 \sqrt{P}$
Radiated RF IEC 61000-4-3	3V/m 80 MHz to 2.5 GHz	3 V/m	$d = 1.2 \sqrt{P}$ 80 MHz to 800 MHz $d = 2.3 \sqrt{P}$ 800 MHz to 2.5 GHz
			where P is the maximum output power rating of the transmitter in watts (W) according to the transmitter manufacturer and d is the recommended separation distance in meters (m). Field strengths from fixed RF transmitters, as determined by the electromagnetic site survey, ^a should be less than the compliance level in each frequency range. ^b Interference may occur in the vicinity of equipment marked with the following symbol: 
NOTE 1: At 80 MHz and 800 MHz, the higher frequency range applies.			
NOTE 2: These guidelines may not apply in all situations. Electromagnetic propagation is affected by absorption and reflection from structures, objects, and people.			
(a) Field strengths from fixed transmitters, such as base stations for radio (cellular/cordless) telephones and land mobile radios, amateur radio, AM and FM radio broadcast, and TV broadcast, cannot be predicted theoretically with accuracy. To assess the electromagnetic environment due to fixed RF transmitters, an electromagnetic site survey should be considered. If the measured field strength in the location in which the system is used exceeds the applicable RF compliance level above, the system should be observed to verify normal operation. If abnormal performance is observed, additional measures may be necessary, such as reorienting or relocating the system.			
(b) Over the frequency range 150 kHz to 80 MHz, field strengths should be less than 3 V/m.			

Recommended Separation Distances Between Portable and Mobile RF Communications Equipment and the System			
The system is intended for use in an electromagnetic environment in which radiated RF disturbances are controlled. The user of the system can help prevent electromagnetic interference by maintaining a minimum distance between portable and mobile RF communications equipment (transmitters) and the system as recommended below, according to the maximum output power of the communications equipment.			
Rated maximum output power (W) of transmitter	Separation distance (m) according to frequency of transmitter		
	150 kHz to 80 MHz $d = 1.2\sqrt{P}$	80 MHz to 800 MHz $d = 1.2\sqrt{P}$	800 MHz to 2.5 GHz $d = 2.3\sqrt{P}$
0.01	0.12	0.12	0.23
0.1	0.38	0.38	0.73
1	1.2	1.2	2.3
10	3.8	3.8	7.3
100	12	12	23
For transmitters rated at a maximum output power not listed above, the recommended separation distance (d) in meters (m) can be estimated using the equation applicable to the frequency of the transmitter, where P is the maximum output power rating of the transmitter in watts (W) according to the transmitter manufacturer.			
NOTE 1 At 80 MHz and 800 MHz, the separation distance for the higher frequency range applies.			
NOTE 2 These guidelines may not apply in all situations. Electromagnetic propagation is affected by absorption and reflection from structures, objects, and people.			

Data Modem Specifications

Below are the data modem specifications for the following modem models: MTSMC-LAT3 and MTSMC-H5. The data modem is a 4G LTE with HSPA+ fallback embedded cellular modem:

Manufacturer: Multitech
 Model: MTSMC-LAT3
 IC 5131A-LE910NAV2
 FCC ID RI7LE910NAV2

Use the modem only with the antenna provided by ZELTIQ.

Frequencies	Network Type	Effective Radiated Power
700MHz (B12/B13) / 850MHz (B5) /AWS 1700MHz (B4)/ 1900MHz (B2)	4G	0.2W
850MHz (B5) /1900MHz (B2)	HSPA+ (3G)	0.25W

Table 26: Data Modem Transmission Specifications

Data Modem Specifications

The data modem is a GPRS wireless modem:

Manufacturer: Multitech
 Model: MTSMC-H5
 IC 5131A-HE910
 FCC ID RI7HE910

Use the modem only with the antenna provided by ZELTIQ.

Frequencies	Network Type	Effective Radiated Power
850/900/1700/1900/2100 MHz	HSPA+ (3G)	0.226 to 1.995 watts
850/900/1800/1900 MHz	GSM/GPRS/EDGE (2G)	0.226 to 1.995 watts

Table 27: Data Modem Transmission Specifications

Electromagnetic Compatibility Compliance - Data Modem

The CoolSculpting System with the data modem complies with the following medical safety standards:

- EN 60601-1-2: 2007 (provides the presumption of compliance to the Medical Device Directive 93 / 42 / EEC as amended by 2007 / 47 / EC).

The limits are designed to provide reasonable protection against harmful interference in a typical medical installation. This equipment generates, uses, and can radiate radio frequency energy and, if not installed and used in accordance with the instruction manual, may cause harmful interference to radio communications. There is no guarantee that interference will be prevented by following the manufacturer's instructions in a particular installation.

If this equipment causes interference with other devices, which may be determined by turning the equipment off and on, the user is encouraged to try to correct the interference by carrying out one or more of the following measures:

- Reorient or relocate the device receiving the interference.
- Increase the separation between the equipment and the device receiving the interference.
- Connect the equipment into an outlet on a circuit different from that to which the other device(s) are connected.
- Consult the manufacturer or field service technician for help.

Data Modem - Canada

The CoolSculpting System with the data modem complies with RSS-210 of Industry Canada. Operation is subject to the following two conditions:

1. This device may not cause interference;
2. This device must accept any interference, including interference that may cause undesired operation of the device.

Data Modem - European Union

CE Notice (European Notice): The Conformité Européenne symbol found on this product indicates compliance to the Medical Device (93 / 42 / EEC) and Radio and Telecommunications Terminal Equipment (1999 / 5 / EC) Directives of the European Union.

The CoolSculpting System with the data modem meets the following technical standards for EMC and radio compliance:

- EN 60601-1-2: 2007
- EN 301-489-17
- EN 301-489-1
- EN 300328 V1.7.1

United States of America

The CoolSculpting System with the data modem has been tested and found to comply with the limits for a Class A digital device, pursuant to part 15 of the FCC Rules. These limits are designed to provide reasonable protection against harmful interference when the equipment is operated in a commercial environment. This equipment generates, uses, and can radiate radio frequency energy and, if not installed and used in accordance with the instruction manual, may cause harmful interference to radio communications. Operation of this equipment in a residential area is likely to cause harmful interference in which case the user will be required to correct the interference at his own expense.

ZELTIQ Aesthetics, Inc.
4410 Rosewood Drive
Pleasanton, CA 94588 USA
(925) 474-2500
www.coolsculpting.com

12/2018